

The image features a blurred green car in motion, with a dotted pattern at the bottom. The car is shown from the side, with the front wheel and side mirror visible. The background is a blurred green and white, suggesting a road or track. The overall aesthetic is dynamic and modern.

**autoneum**

**June 4, 2025**

# Roadshow Frankfurt

Autoneum. Mastering sound and heat.

## Key financials

**2338.7**

CHF million  
Revenue

**5.3%**

EBIT margin

**70.0**

CHF million  
Net result

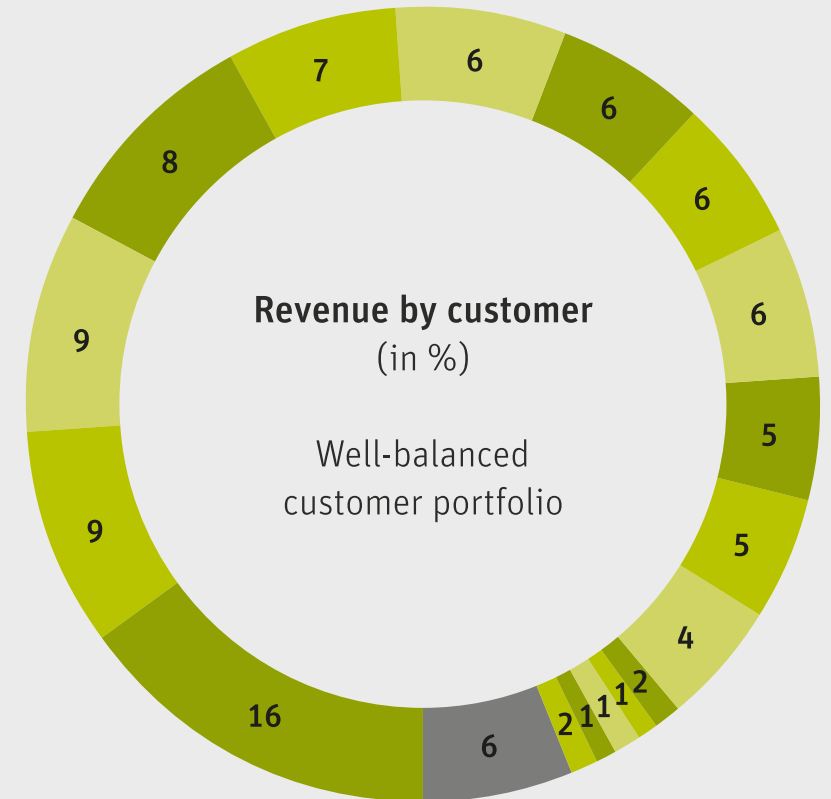
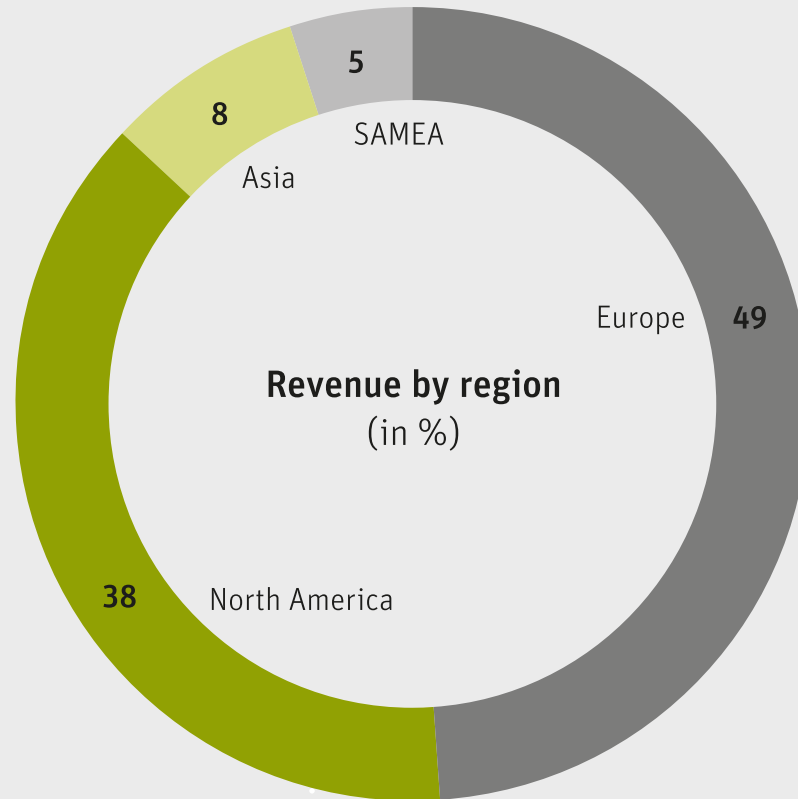

- Light vehicles
- Commercial vehicles

## 2024 Highlights

# Guidance from March 2024 clearly achieved



### Revenue growth in slightly shrinking market

- Revenue in local currencies increased by 4.2%
- Revenue of CHF 2338.7 million
- Record order intake



### Solid financial performance further improved

- EBIT margin of 5.3%
- Free cash flow of CHF 109.7 million
- Dividend of CHF 2.80 per share (2023: CHF 2.50)



### New guiding principles and strategy

- Global roll-out of new mission, vision, purpose and values
- Launch of new Level Up corporate strategy



### Important steps in focus area Asia, mainly China

- Acquisition of majority shareholding in Jiangsu Huanyu Group
- Opening of new plants in Pune, India, and Changchun, China

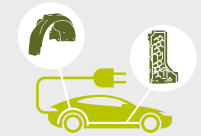

### Technology and sustainability leadership

- Expansion of sustainable product portfolio for light vehicles and trucks
- Establishment of specialized New Mobility Team
- Opening of new R&T Center in Shanghai, China

## Accelerate global growth

# Significant increase in order book due to record order intake

CHF billion

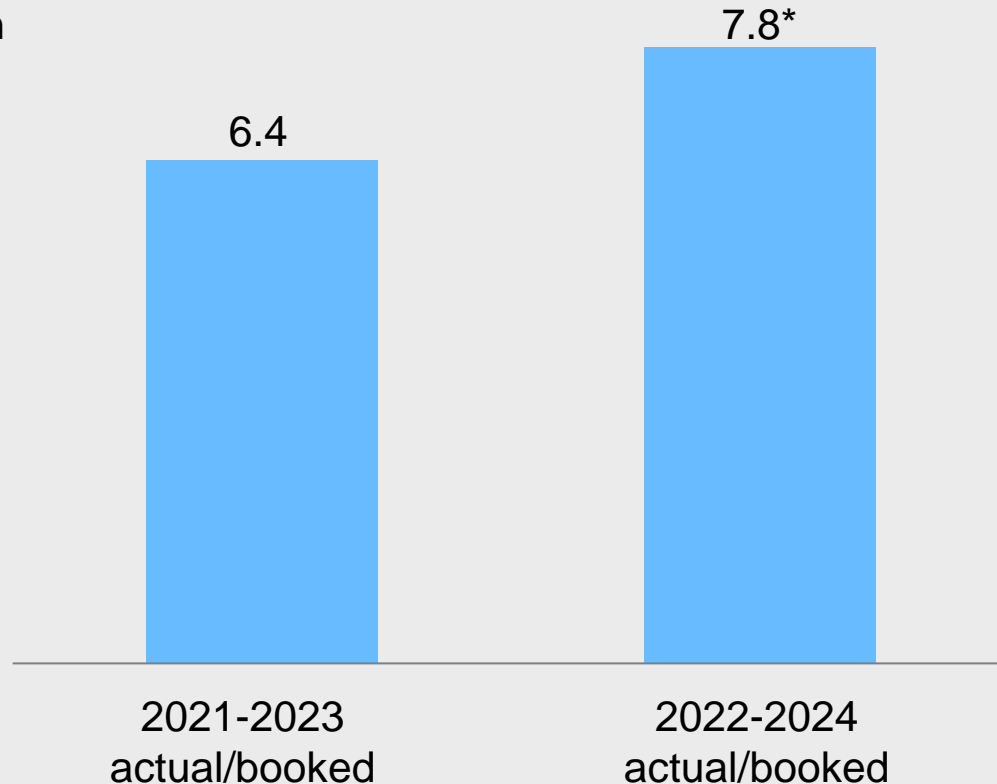

■ Order intake (3 years rolling lifetime revenue)

New business awards received  
in 2024 of CHF 3.2 billion  
(lifetime revenue)

\* Lifetime revenue based on S&P Global Mobility Light Vehicle Production Market Forecast of January 2025.

## Important steps toward a sustainable future

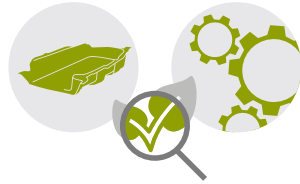

Resource-efficient products and production processes

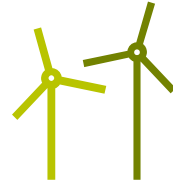

Conversion of production plants to **renewable electricity**

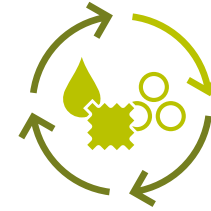

Material design focused on **re-use and recycling**



Implementing **community engagement projects** across the globe



Pioneering **sustainability labels**



Responsible **sourcing** across the entire value chain



Improving **energy management** in all plants



Reducing **greenhouse gas emissions** in line with the criteria of the Science Based Targets initiative

# Medium-term targets

## Financial and ESG targets well on track

### Financial targets



**Revenue**  
CHF 3 billion\*

2024  
CHF 2.3 billion



**EBIT margin**  
6% to 8%  
over the cycle

2024  
5.3%



**Free cash flow**  
>5% of revenue

2024  
4.7%



**Net debt to EBITDA**  
(incl. IFRS 16)  
<1.5x

Dec. 31, 2024  
1.6x

### ESG targets

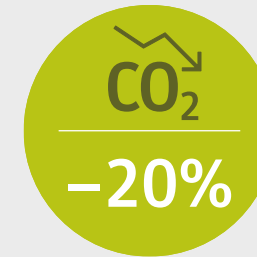

**CO<sub>2</sub> emissions**  
**Scope 1 and 2**  
Reduce by 20%\*\*

2024  
22.8%



**Non-hazardous**  
**waste**  
Reduce by 40%\*\*

2024  
38.5%



*Pro memoria:* Unchanged policy of dividend payout of at least 30% of net profit attributable to shareholders of Autoneum Holding Ltd

\* At 2024 foreign currency exchange rates.

\*\* Baseline 2019, to be reached by 2027.

# Guidance 2025

---



## Revenue

According to the latest market forecast\*, automobile production will show no growth in 2025. Consequently, Autoneum expects revenue of CHF 2.3 to 2.5 billion for the 2025 financial year, which includes the acquisition of Jiangsu Huanyu Group, effective February 28, 2025.

\*Source: S&P Global Mobility Light Vehicle Production Market Forecast of February 18, 2025.



## Profitability and free cash flow

Based on the expected revenue, for the 2025 financial year Autoneum anticipates an EBIT margin of 5% to 6% and a free cash flow of around CHF 100 million (excluding the one-off net cash outflow for M&A transactions).

# About Autoneum

---



# About Autoneum

## At a glance

---



Stock-listed company  
(SIX Swiss Exchange)



Represented in 25  
countries

## 2024 in review

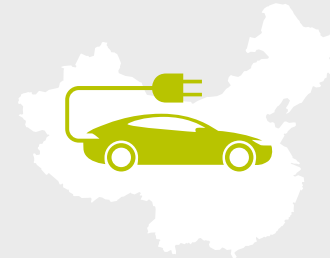

Opening of new Research &  
Technology Center in China

  
**LEVEL UP**

Introduction of new  
corporate strategy Level Up

  
**~16500**

employees



77 production facilities  
worldwide



Extension of sustainable polyester-  
based product portfolio to  
commercial vehicles



Fully recyclable trunk side trim  
made of 100% polyester

# History

## 120 years of expertise

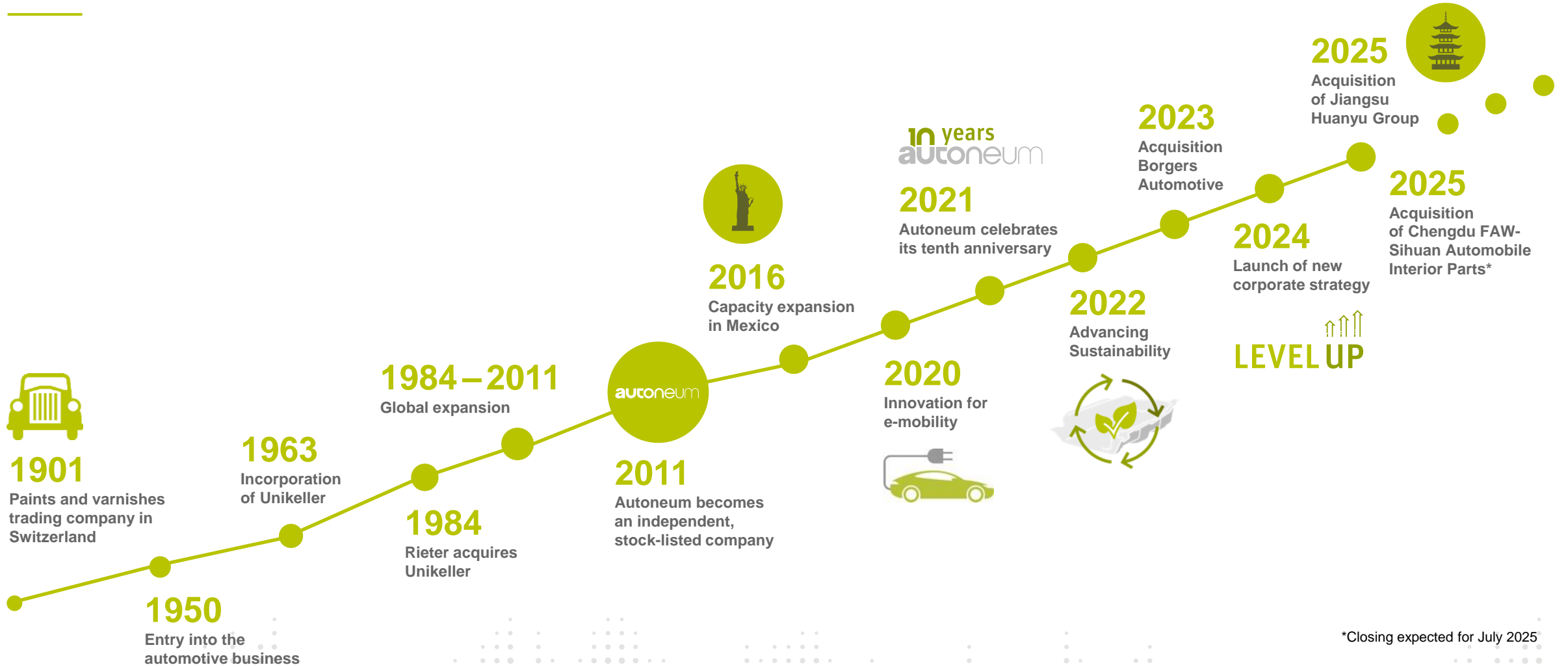

\*Closing expected for July 2025

## Our Purpose, Vision, Mission & Values

### Purpose:

We care to make mobility comfortable and sustainable.

### Vision:

Be the global leader for innovative and sustainable solutions bringing comfort to every vehicle.

### Mission:

We expand our global market and technology leadership mastering vehicle acoustics, thermal management and shielding technologies.

We act as one team to turn opportunities into realities - for all our stakeholders and the world we live in.

### Values:



ACCOUNTABILITY



CURIOSITY



COLLABORATION



COURAGE

## Strategic priorities

---



Shape a future-fit product portfolio



Innovate to create customer value



Accelerate global growth



Foster a people centric culture



Be the sustainability benchmark



Boost cost-competitiveness

# Global presence

## Active in all automotive markets

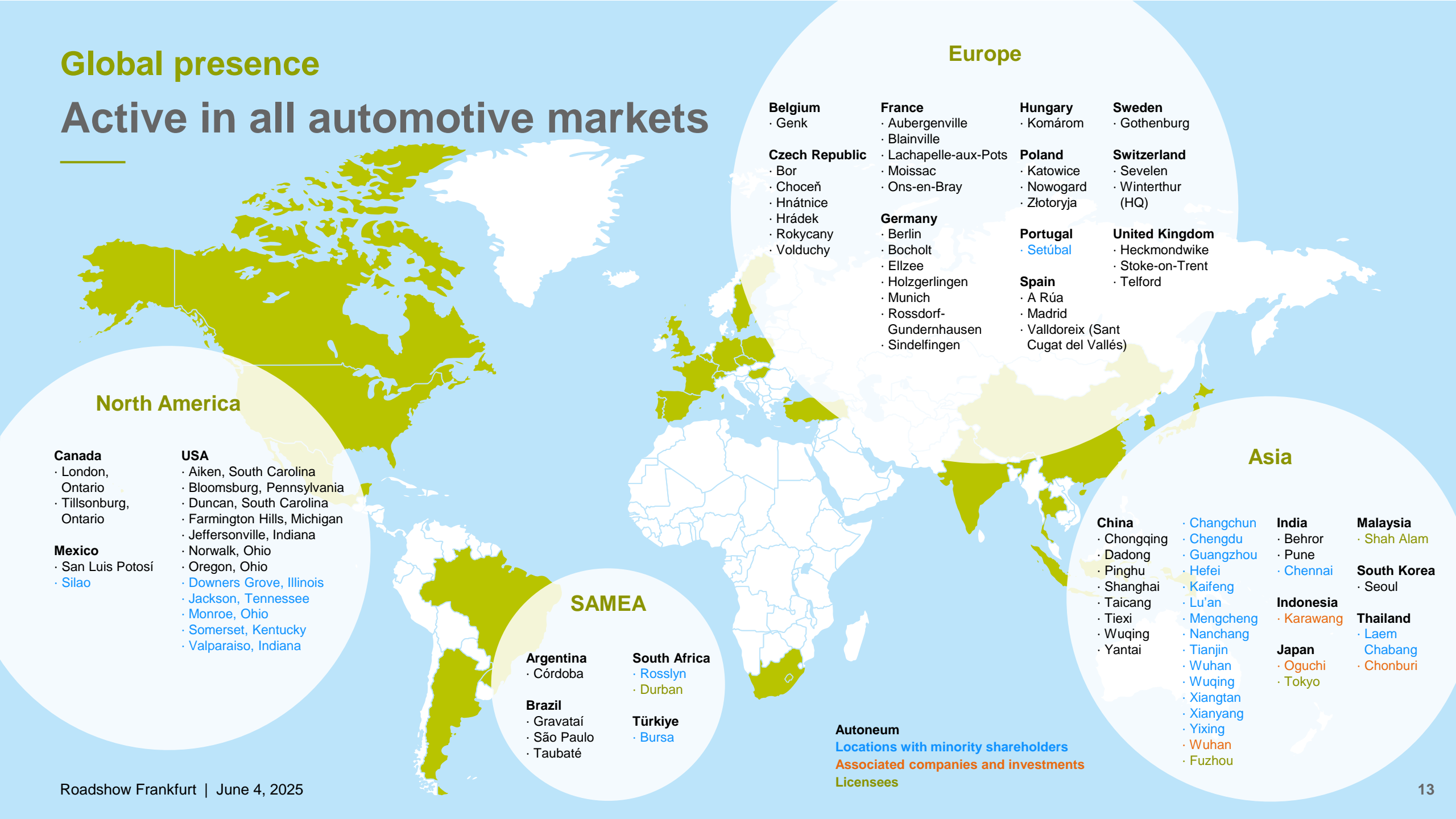

### Europe

- Belgium**
  - Genk
- France**
  - Aubergenville
  - Blainville
  - Lachapelle-aux-Pots
  - Moissac
  - Ons-en-Bray
- Czech Republic**
  - Bor
  - Choceň
  - Hnátnice
  - Hrádek
  - Rokycany
  - Volduchy
- Germany**
  - Berlin
  - Bocholt
  - Ellzee
  - Holzgerlingen
  - Munich
  - Rossdorf-Gundernhausen
  - Sindelfingen
- Hungary**
  - Komárom
- Poland**
  - Katowice
  - Nowogard
  - Złotoryja
- Portugal**
  - **Setúbal**
- Spain**
  - A Rúa
  - Madrid
  - Valldoreix (Sant Cugat del Vallés)
- Sweden**
  - Gothenburg
- Switzerland**
  - Sevelen
  - Winterthur (HQ)
- United Kingdom**
  - Heckmondwike
  - Stoke-on-Trent
  - Telford

### North America

- Canada**
  - London, Ontario
  - Tillsonburg, Ontario
- Mexico**
  - San Luis Potosí
  - **Silao**
- USA**
  - Aiken, South Carolina
  - Bloomsburg, Pennsylvania
  - Duncan, South Carolina
  - Farmington Hills, Michigan
  - Jeffersonville, Indiana
  - Norwalk, Ohio
  - Oregon, Ohio
  - **Downers Grove, Illinois**
  - **Jackson, Tennessee**
  - **Monroe, Ohio**
  - **Somerset, Kentucky**
  - **Valparaiso, Indiana**

### SAMEA

- Argentina**
  - Córdoba
- Brazil**
  - Gravataí
  - São Paulo
  - Taubaté
- South Africa**
  - **Rossllyn**
  - Durban
- Türkiye**
  - **Bursa**

### Asia

- China**
  - Chongqing
  - Dadong
  - Pinghu
  - Shanghai
  - Taicang
  - Tiexi
  - Wuqing
  - Yantai
- India**
  - Behror
  - Pune
  - **Chennai**
- Indonesia**
  - **Karawang**
- Japan**
  - **Oguchi**
  - Tokyo
- Malaysia**
  - **Shah Alam**
- South Korea**
  - Seoul
- Thailand**
  - **Laem Chabang**
  - **Chonburi**
- China (continued)**
  - **Changchun**
  - **Chengdu**
  - **Guangzhou**
  - **Hefei**
  - **Kaifeng**
  - **Lu'an**
  - **Mengcheng**
  - **Nanchang**
  - **Tianjin**
  - **Wuhan**
  - **Wuqing**
  - **Xiangtan**
  - **Xianyang**
  - **Yixing**
  - **Wuhan**
  - **Fuzhou**

**Autoneum**  
 Locations with minority shareholders  
 Associated companies and investments  
 Licensees

# Most car manufacturers worldwide



## Our products for light vehicles of all drive types

### Exterior

#### Engine bay

- Frunk
- Engine\* and e-motor encapsulations
- Outer dashes
- Outer trunk floor insulators
- Hoodliners
- Engine top covers\*

#### Underbody

- Underbody shields
- Under battery shields
- Wheelhouse outer liners
- Outer tunnel insulators\*
- Heatshields\*
- Battery electromagnetic shields
- Outer floor insulators

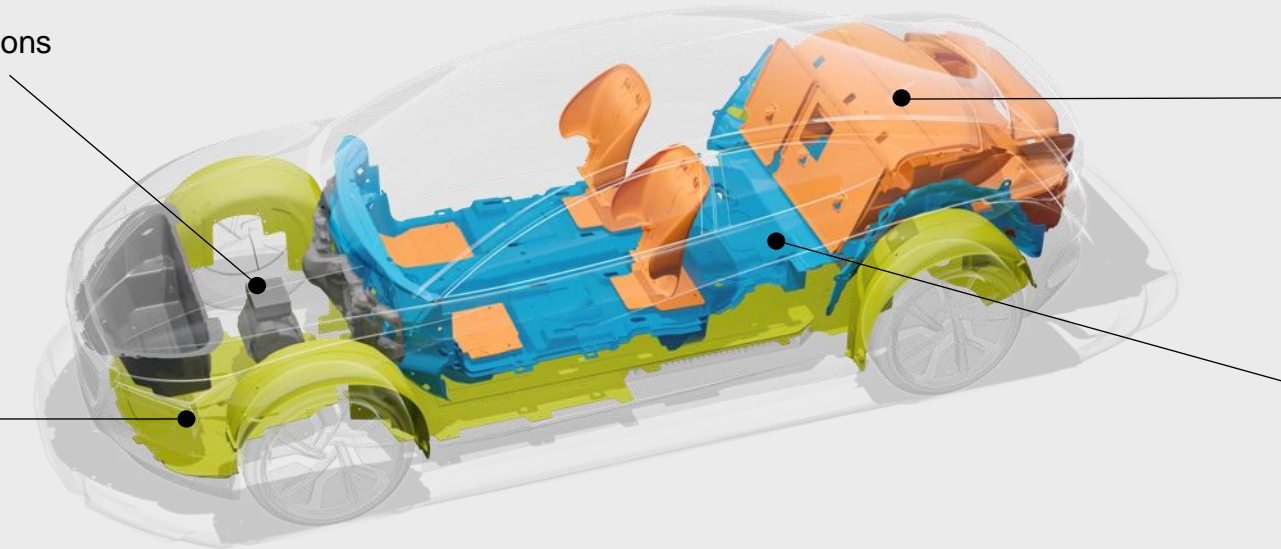

### Interior

#### Interior trim

- Trunk side trim
- Trunk load floors
- Trunk tailgate trim
- Parcel shelves
- Trunk floor carpets
- Trunk floor trim
- Floor mats
- Back seat trim

#### Interior floor

- Inner dashes
- Needlepunch carpets
- Tufted carpets
- Floor insulators
- Inner wheelhouse insulators
- Inner trunk floor insulators
- Washable surface flooring

\* Components specifically for vehicles with combustion drive

# The impact protection plate and flame shield

### Impact protection plate:

- High impact resistance
- No permanent deformation
- No warpage

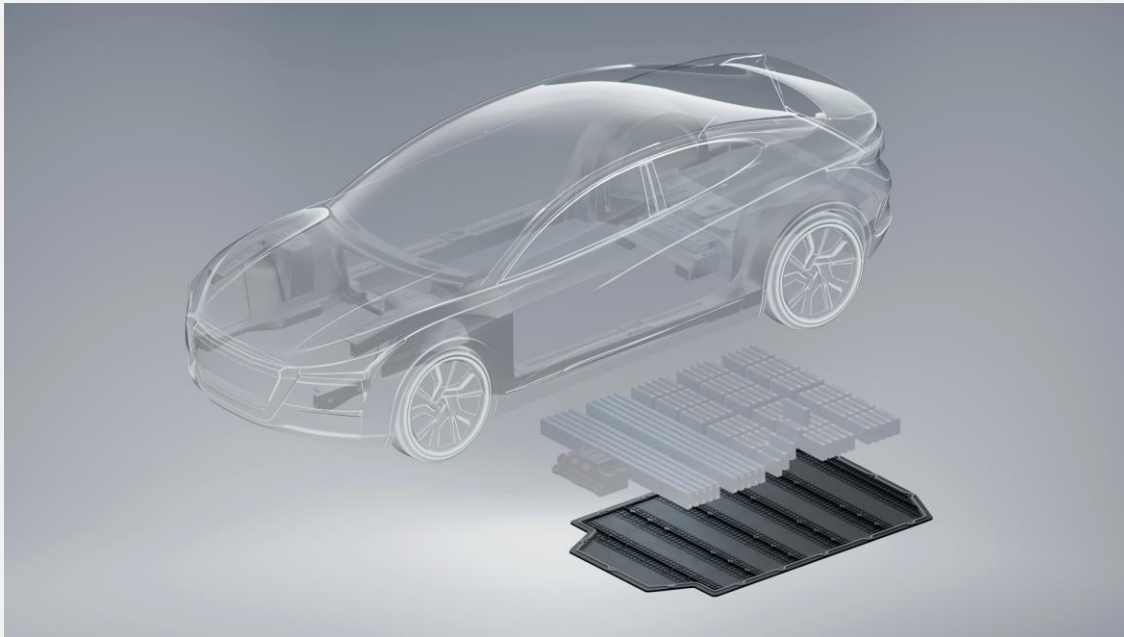

### Flame shield:

- >1400°C local temperature
- Resist to hot particle abrasion
- Ensure 5 minutes escape law

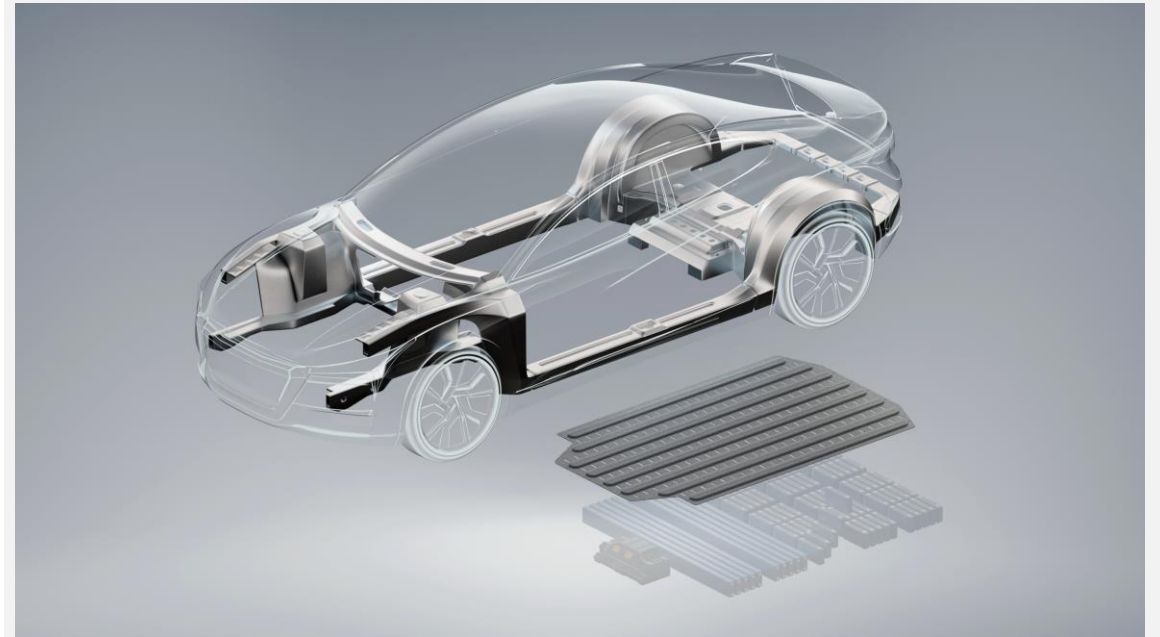

# Leading in acoustic and thermal management

## Our products for commercial vehicles

### Exterior

#### Engine bay

- E-motor and accessory encapsulations
- Engine and gearbox encapsulations\*
- Noise shields

#### Underbody

- Under engine shields
- Heatshields\*

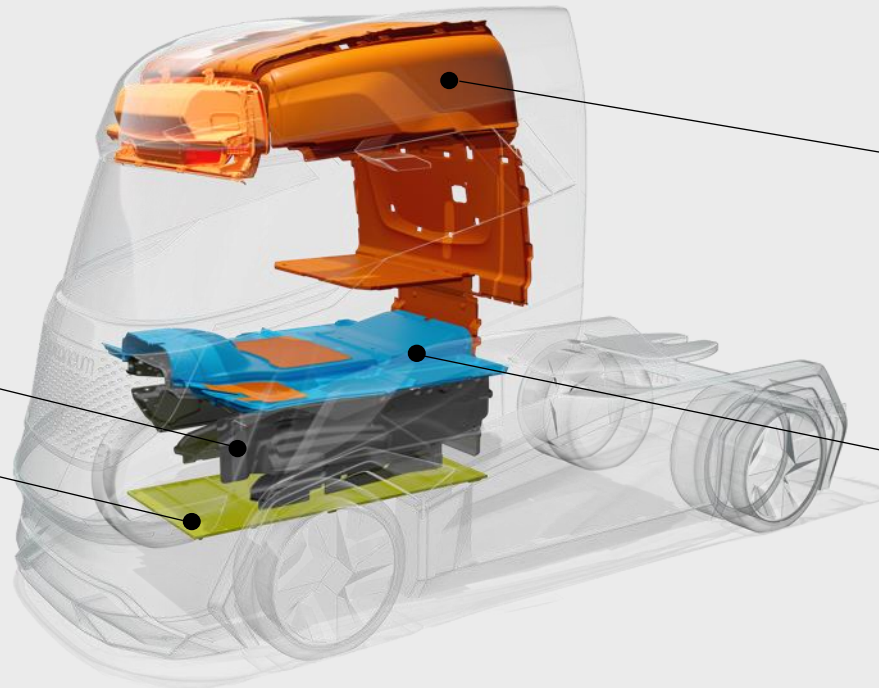

### Interior

#### Interior trim

- Headliners
- Side and rear panels
- (Heated) Floor mats
- Upper storage
- Bunk bed support

#### Interior floor

- Washable surface flooring
- Carpet systems
- Dampers

\* Components specifically for vehicles with combustion drive

# Contact

---



# Contact persons

---

## Investors and financial analysts

Bernhard Weber  
Head Financial Services & IR

T +41 52 244 82 07

[investor@autoneum.com](mailto:investor@autoneum.com)

## Media

Ulrike Reich  
Head Corporate Communications

T +41 52 244 83 88

[media.inquiry@autoneum.com](mailto:media.inquiry@autoneum.com)

## Contact address

Autoneum Holding Ltd  
Schlosstalstrasse 43 / P.O. Box  
CH-8406 Winterthur

[www.autoneum.com](http://www.autoneum.com)

## Important dates

Semi-Annual Report 2025

July 30, 2025

Annual General Meeting 2026

April 29, 2026

## SIX Swiss Exchange stock listing:

Ticker symbol	AUTN
Securities number	12748036
ISIN	CH0127480363

autoneum

Autoneum. Mastering sound and heat.

