

The image features a blurred green car in motion on a road, with a dotted pattern at the bottom. The car is on the left side, and the background is a blurred road with green and white stripes. The text 'autoneum' is in the top right, 'August 28, 2025' is below it, and 'Roadshow Zurich' is in the center right. The tagline 'Autoneum. Mastering sound and heat.' is at the bottom right.

autoneum

August 28, 2025

# Roadshow Zurich

Autoneum. Mastering sound and heat.

# Key Figures Overview

CHF million	HY1 2024	HY1 2025	Change
Revenue	1212.3	<b>1171.6</b>	-40.8
EBITDA	128.1	<b>125.8</b>	-2.4
<i>in % of revenue</i>	<i>10.6%</i>	<i><b>10.7%</b></i>	
EBIT	65.8	<b>61.9</b>	-3.9
<i>in % of revenue</i>	<i>5.4%</i>	<i><b>5.3%</b></i>	
Net result	36.1	<b>40.7</b>	4.6
Free cash flow*	39.1	<b>48.4*</b>	9.3
Basic earnings per share (EPS) in CHF	4.86	<b>5.16</b>	0.29

\* HY1 2025 free cash flow excl. one-off M&A-related net cash outflow

## Solid Performance in a Challenging Market



Resilient EBIT margin, only slightly below prior-year period



Free cash flow on track for 2025 target



Net result significantly improved



Jiangsu Huanyu acquisition contributing positively to Group performance



Successful turnaround in North America confirmed



Expansion of sustainable product portfolio

# Strong Regional Performance Across All Markets

## Driving Forward With Sustained Strength and Confidence



**Europe:** Fairly stable EBIT margin despite market decline



**Asia:** Revenue boost from acquisitions, EBIT up



**North America:** Turnaround confirmed, EBIT margin at 5.1%



**SAMEA:** Best-in-class EBIT margin of 14.7%

# Market Outlook: Light Vehicle Production Forecast

## Global Stable Volumes Expected in 2025

### Annual Global Automobile Production

million units

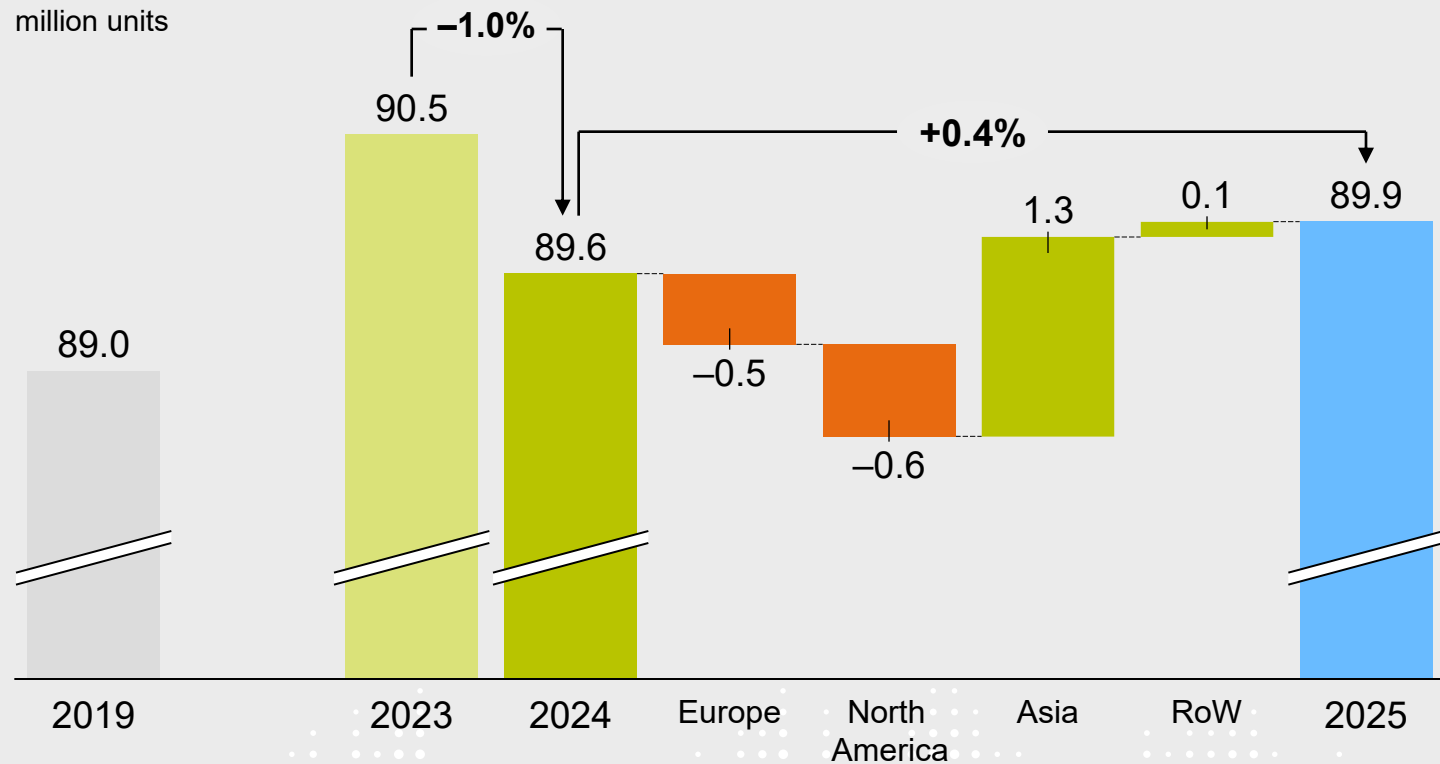

- Small increase of +0.4% expected in 2025
- Market in decline in Europe and North America. Increase in Asia and ROW
- Second half-year is expected to be slightly above (+0.4%) the first half of 2025

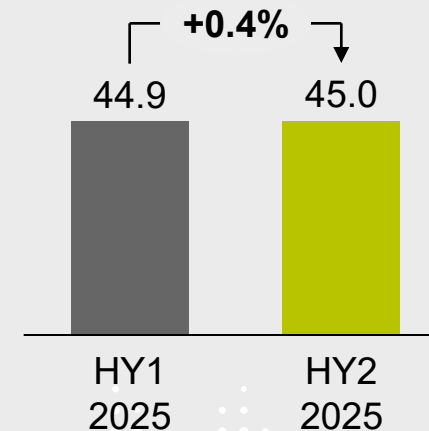

\*Source: S&P Global Light Vehicle Production of July 2025

# Guidance 2025, Issued in March 2025, Still Valid



## Revenue

According to the February market forecast\*, automobile production will show no growth in 2025. Consequently, Autoneum expects revenue of CHF 2.3 to 2.5 billion for the 2025 financial year, which includes the acquisition of Jiangsu Huanyu Group, effective February 28, 2025.



## Profitability and free cash flow

Based on the expected revenue, for the 2025 financial year Autoneum anticipates an EBIT margin of 5% to 6% and a free cash flow of around CHF 100 million (excluding the one-off net cash outflow for M&A transactions).

\*Source: S&P Global Mobility Light Vehicle Production Market Forecast of February 18, 2025.

# About Autoneum

---



# About Autoneum

## At a Glance

---



Stock-listed company  
(SIX Swiss Exchange)



Represented in 25  
countries

## 2024 in review

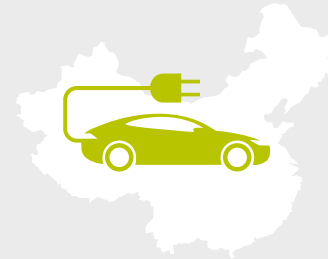

Opening of new Research &  
Technology Center in China

  
**LEVEL UP**

Introduction of new  
corporate strategy Level Up

  
**~16 500**

employees



77 production facilities  
worldwide



Extension of sustainable polyester-  
based product portfolio to  
commercial vehicles



Fully recyclable trunk side trim  
made of 100% polyester

## Key Financials

**2338.7**

CHF million  
**Revenue**

**5.3%**

**EBIT margin**

**70.0**

CHF million  
**Net result**

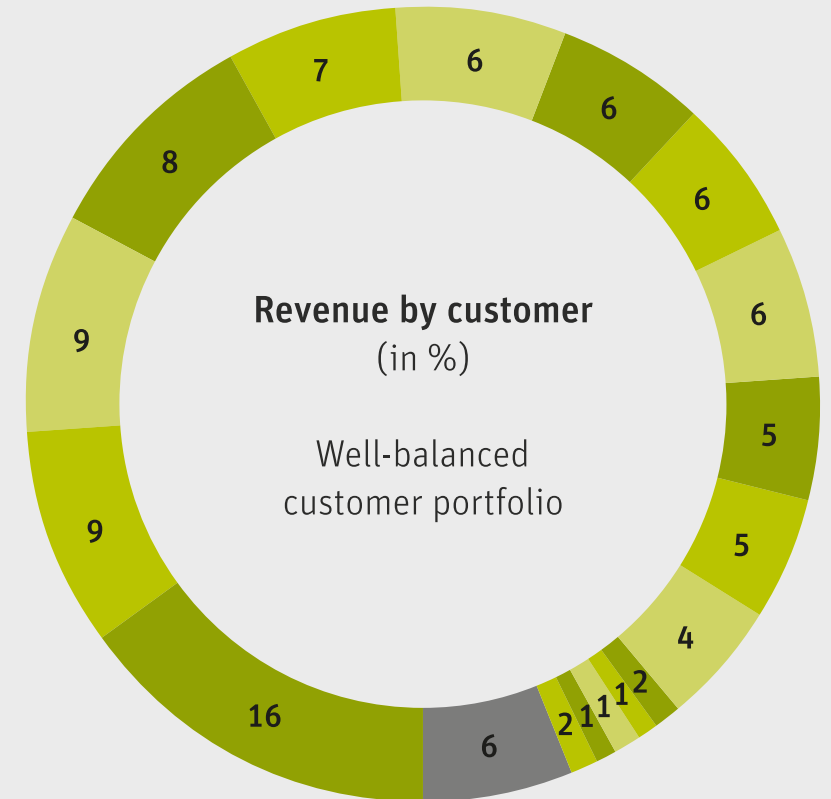
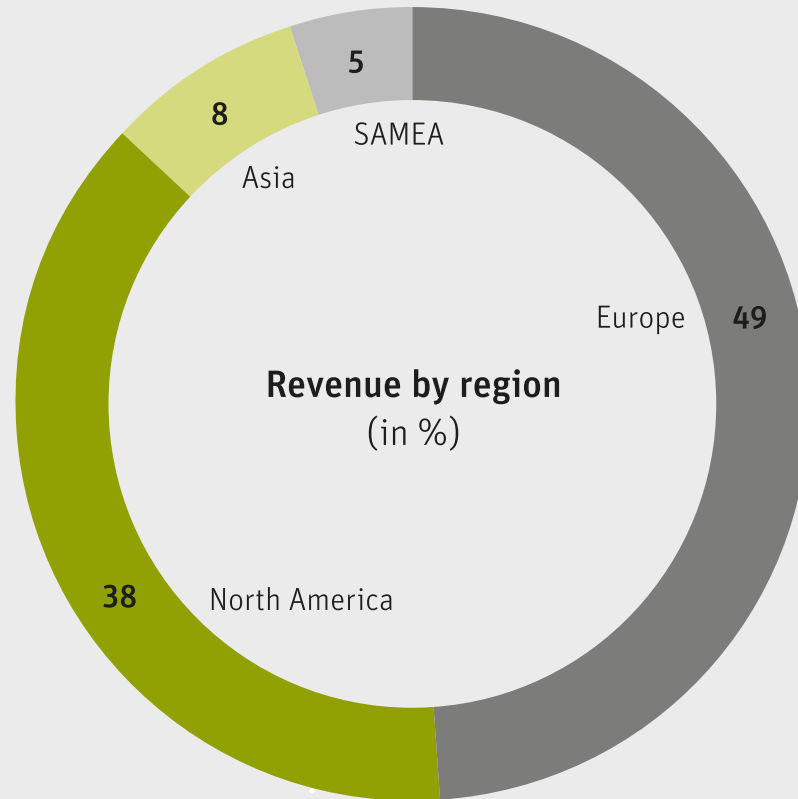

# History

## 120 Years of Expertise

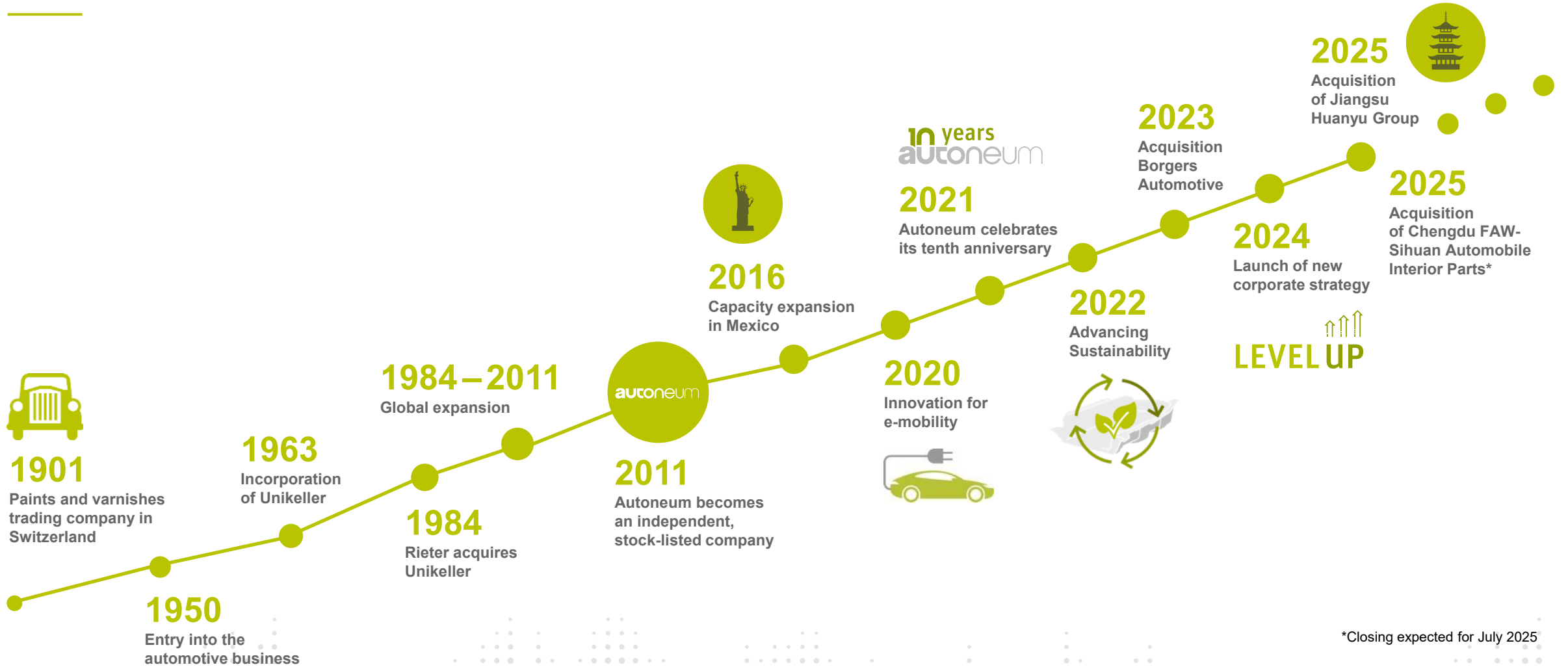

\*Closing expected for July 2025

## Our Purpose, Vision, Mission & Values

### Purpose:

We care to make mobility comfortable and sustainable.

### Vision:

Be the global leader for innovative and sustainable solutions bringing comfort to every vehicle.

### Mission:

We expand our global market and technology leadership mastering vehicle acoustics, thermal management and shielding technologies.

We act as one team to turn opportunities into realities - for all our stakeholders and the world we live in.

### Values:



ACCOUNTABILITY



CURIOSITY



COLLABORATION



COURAGE



Shape a future-fit product portfolio



Innovate to create customer value



Accelerate global growth



Foster a people centric culture



Be the sustainability benchmark



Boost cost-competitiveness

# Global Presence

## Active in All Automotive Markets

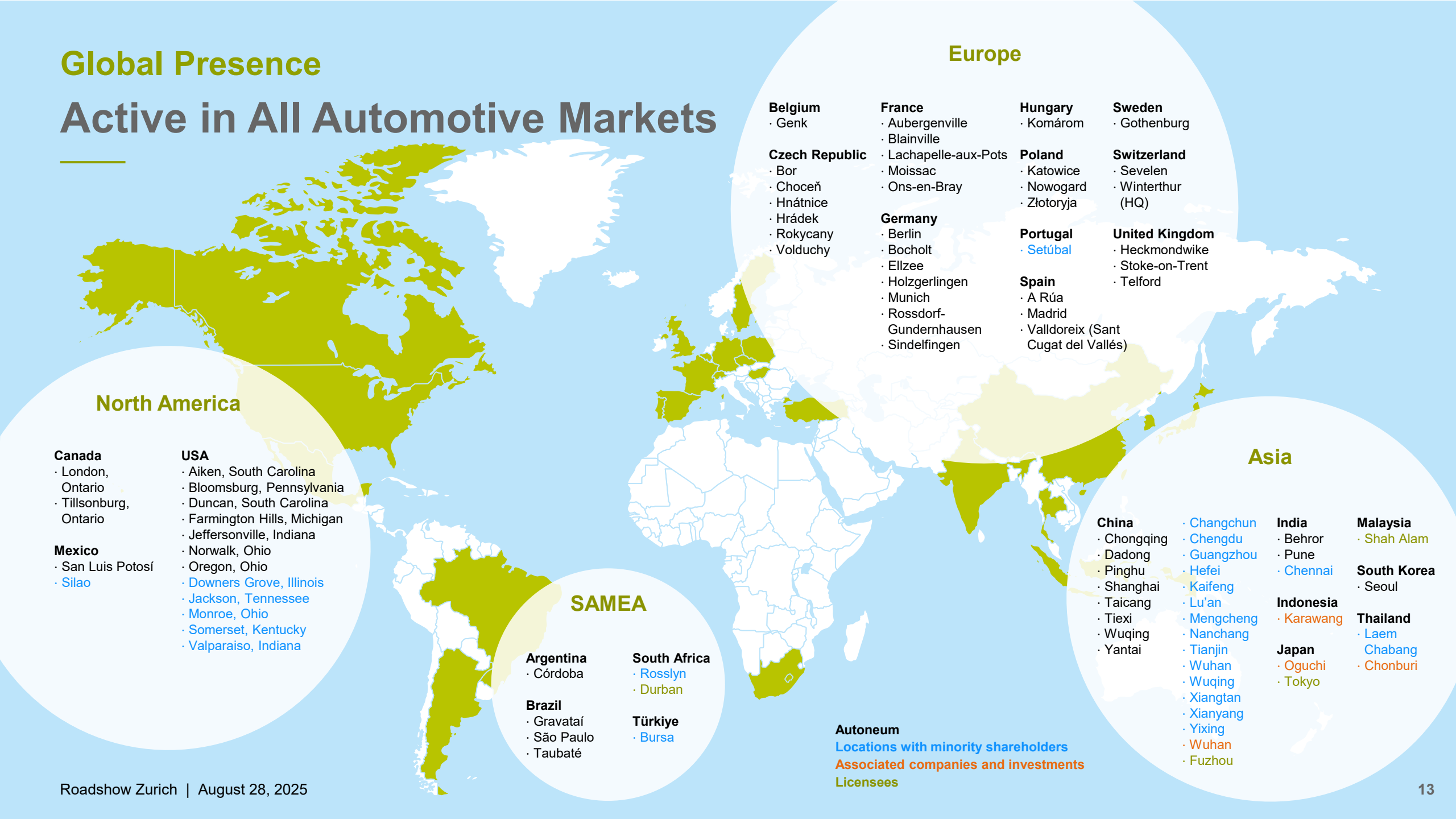

### North America

#### Canada

- London, Ontario
- Tillsonburg, Ontario

#### Mexico

- San Luis Potosí
- Silao

#### USA

- Aiken, South Carolina
- Bloomsburg, Pennsylvania
- Duncan, South Carolina
- Farmington Hills, Michigan
- Jeffersonville, Indiana
- Norwalk, Ohio
- Oregon, Ohio
- Downers Grove, Illinois
- Jackson, Tennessee
- Monroe, Ohio
- Somerset, Kentucky
- Valparaiso, Indiana

### SAMEA

#### Argentina

- Córdoba

#### Brazil

- Gravataí
- São Paulo
- Taubaté

#### South Africa

- Rosslyn
- Durban

#### Türkiye

- Bursa

### Europe

#### Belgium

- Genk

#### Czech Republic

- Bor
- Choceň
- Hnátnice
- Hrádek
- Rokycany
- Volduchy

#### France

- Aubergenville
- Blainville
- Lachapelle-aux-Pots
- Moissac
- Ons-en-Bray

#### Germany

- Berlin
- Bocholt
- Ellzee
- Holzgerlingen
- Munich
- Rossdorf-Gundernhausen
- Sindelfingen

#### Hungary

- Komárom

#### Poland

- Katowice
- Nowogard
- Złotoryja

#### Portugal

- Setúbal

#### Spain

- A Rúa
- Madrid
- Valldoreix (Sant Cugat del Vallés)

#### Sweden

- Gothenburg

#### Switzerland

- Sevelen
- Winterthur (HQ)

#### United Kingdom

- Heckmondwike
- Stoke-on-Trent
- Telford

### Asia

#### China

- Chongqing
- Dadong
- Pinghu
- Shanghai
- Taicang
- Tiexi
- Wuqing
- Yantai

#### · Changchun

- Chengdu
- Guangzhou
- Hefei
- Kaifeng
- Lu'an
- Mengcheng
- Nanchang
- Tianjin
- Wuhan
- Wuqing
- Xiangtan
- Xianyang
- Yixing
- Wuhan
- Fuzhou

#### India

- Behror
- Pune
- Chennai
- Karawang
- Tokyo

#### Malaysia

- Shah Alam

#### South Korea

- Seoul

#### Thailand

- Laem Chabang
- Chonburi

#### Autoneum

Locations with minority shareholders

Associated companies and investments

Licensees

# Most Car Manufacturers Worldwide

Light vehicles



Commercial vehicles



## Our Products for Light Vehicles of All Drive Types

### Exterior

#### Engine bay

- Frunk
- Engine\* and e-motor encapsulations
- Outer dashes
- Outer trunk floor insulators
- Hoodliners
- Engine top covers\*

#### Underbody

- Underbody shields
- Under battery shields
- Wheelhouse outer liners
- Outer tunnel insulators\*
- Heatshields\*
- Battery electromagnetic shields
- Outer floor insulators



### Interior

#### Interior trim

- Trunk side trim
- Trunk load floors
- Trunk tailgate trim
- Parcel shelves
- Trunk floor carpets
- Trunk floor trim
- Floor mats
- Back seat trim

#### Interior floor

- Inner dashes
- Needle-punch carpets
- Tufted carpets
- Floor insulators
- Inner wheelhouse insulators
- Inner trunk floor insulators
- Washable surface flooring

\* Components specifically for vehicles with combustion drive

# The Impact Protection Plate and Flame Shield

### Impact protection plate:

- High impact resistance
- No permanent deformation
- No warpage

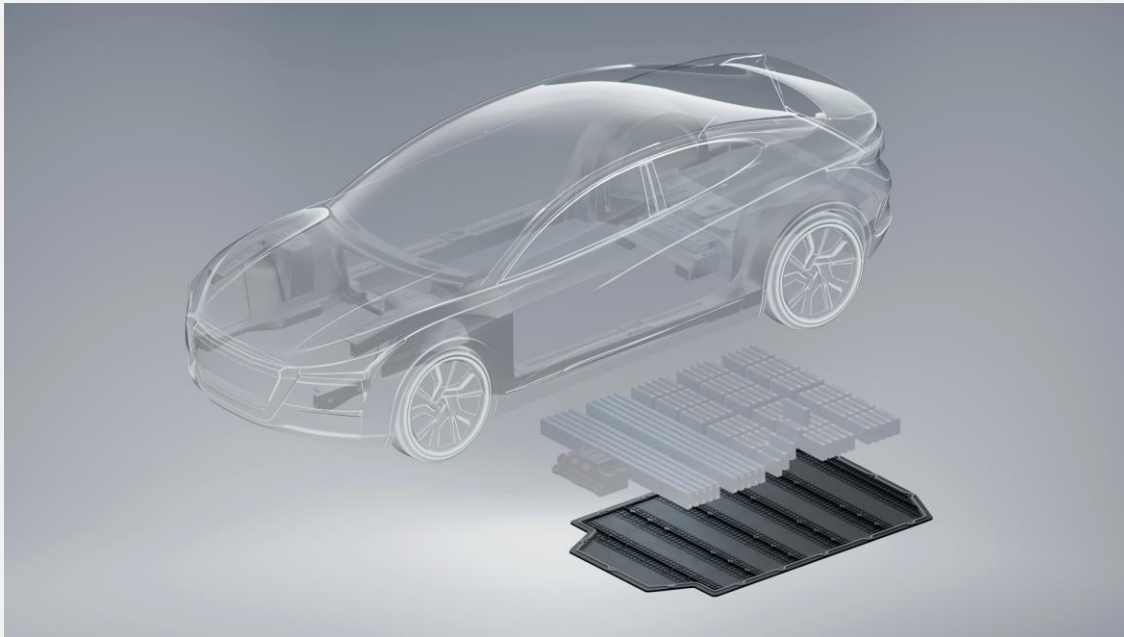

### Flame shield:

- >1400°C local temperature
- Resist to hot particle abrasion
- Ensure 5 minutes escape law

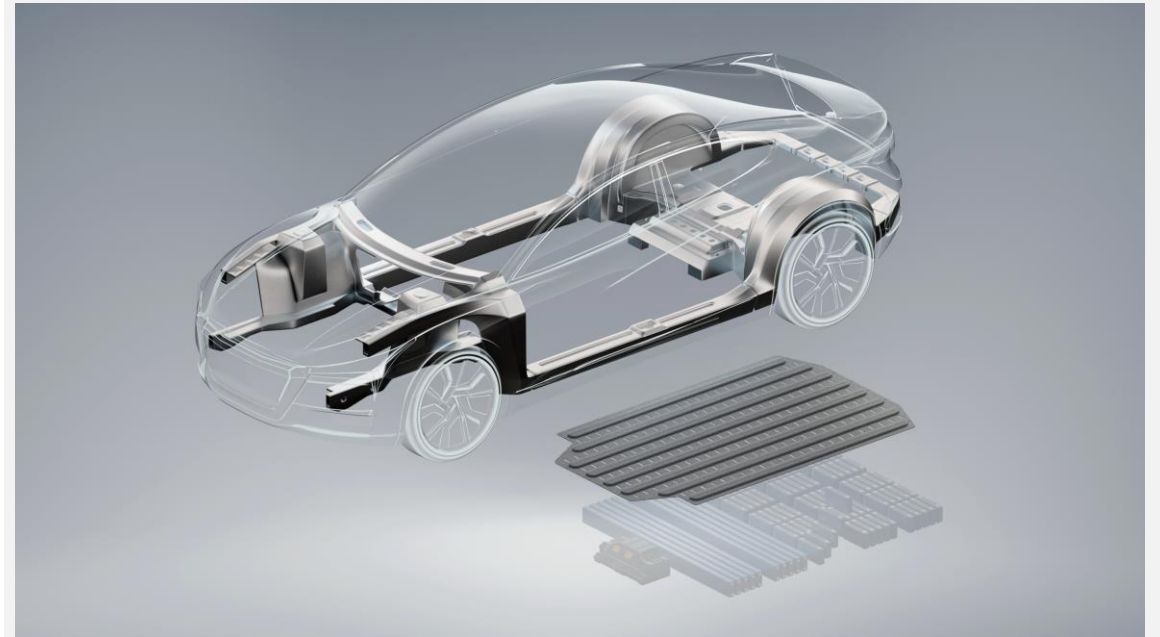

# Leading in Acoustic and Thermal Management

## Our Products for Commercial Vehicles

### Exterior

#### Engine bay

- E-motor and accessory encapsulations
- Engine and gearbox encapsulations\*
- Noise shields

#### Underbody

- Under engine shields
- Heatshields\*

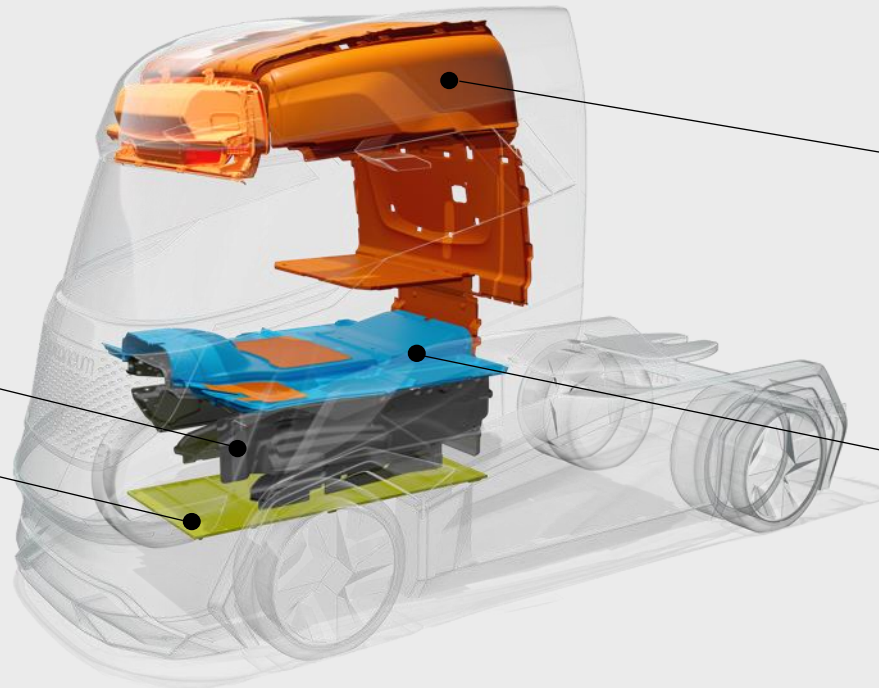

### Interior

#### Interior trim

- Headliners
- Side and rear panels
- (Heated) Floor mats
- Upper storage
- Bunk bed support

#### Interior floor

- Washable surface flooring
- Carpet systems
- Dampers

\* Components specifically for vehicles with combustion drive

# Contact

---



# Contact Persons

---

## Investors and financial analysts

Bernhard Weber  
Head Financial Services & IR

T +41 52 244 82 07

[investor@autoneum.com](mailto:investor@autoneum.com)

## Media

Ulrike Reich  
Head Corporate Communications

T +41 52 244 83 88

[media.inquiry@autoneum.com](mailto:media.inquiry@autoneum.com)

## Contact address

Autoneum Holding Ltd  
Schlosstalstrasse 43 / P.O. Box  
CH-8406 Winterthur

[www.autoneum.com](http://www.autoneum.com)

## Important dates

Publication of Revenue Financial Year 2025

January 23, 2026

Media Conference Financial Year 2025

March 12, 2026

Annual General Meeting 2026

April 28, 2026

## SIX Swiss Exchange stock listing:

Ticker symbol

AUTN

Securities number

12748036

ISIN

CH0127480363

# Disclaimer

---

Autoneum is making great efforts to include accurate and up-to-date information in this document, however, we make no representations or warranties, expressed or implied, as to the accuracy or completeness of the information provided in this document and we disclaim any liability whatsoever for the use of it. Due to rounding, numbers presented throughout this document may not add up precisely to the totals provided. All ratios and variances are calculated using the underlying amount rather than the presented rounded amount.

The information provided in this document is neither intended nor may be construed as an offer or solicitation for the purchase or disposal, trading or any transaction in any Autoneum securities. Investors must not rely on this information for investment decisions.

All statements in this report which do not reflect historical facts are statements related to the future which offer no guarantee with regard to future performance; they are subject to risks and uncertainties including, but not limited to future global economic conditions, exchange rates, legal provisions, market conditions, activities by competitors and other factors outside Autoneum's control. Autoneum assumes no obligation to update any forward-looking statements or to conform them to future events or developments. The vehicle production figures for 2025 and forward looking are based on the latest estimates of S&P Global Mobility Light Vehicle Production Market Forecast.

autoneum

Autoneum. Mastering sound and heat.

